

SPECIFICATION

GT1000AD6-01A

(AC115-230V)

BANKING Machines

ATM Machines



KM electronic components

Carl Zeiss Str.7

68799 Reilingen

0049 6205 6164

info@KM-electronic.com

Design		Issue		Check		Approval		GT1000AD6-01A POWER SUPPLY SPECIFICATIONS
Ref No.								

1. General Description and Scope

This PSU is designed for ATM operation with two stand-by outputs, unit powers of +24V and standard ATX power supply for the system PC. Also the PSU has a too stable and safe battery back-up solution with a lead acid battery charger and protectors for AC interruption. The rated output power is 1000W and the maximum is 1500W and the MCU in the PSU will control all sequences and protect the ATM and itself from the fault conditions.

1.1. System Block Diagram

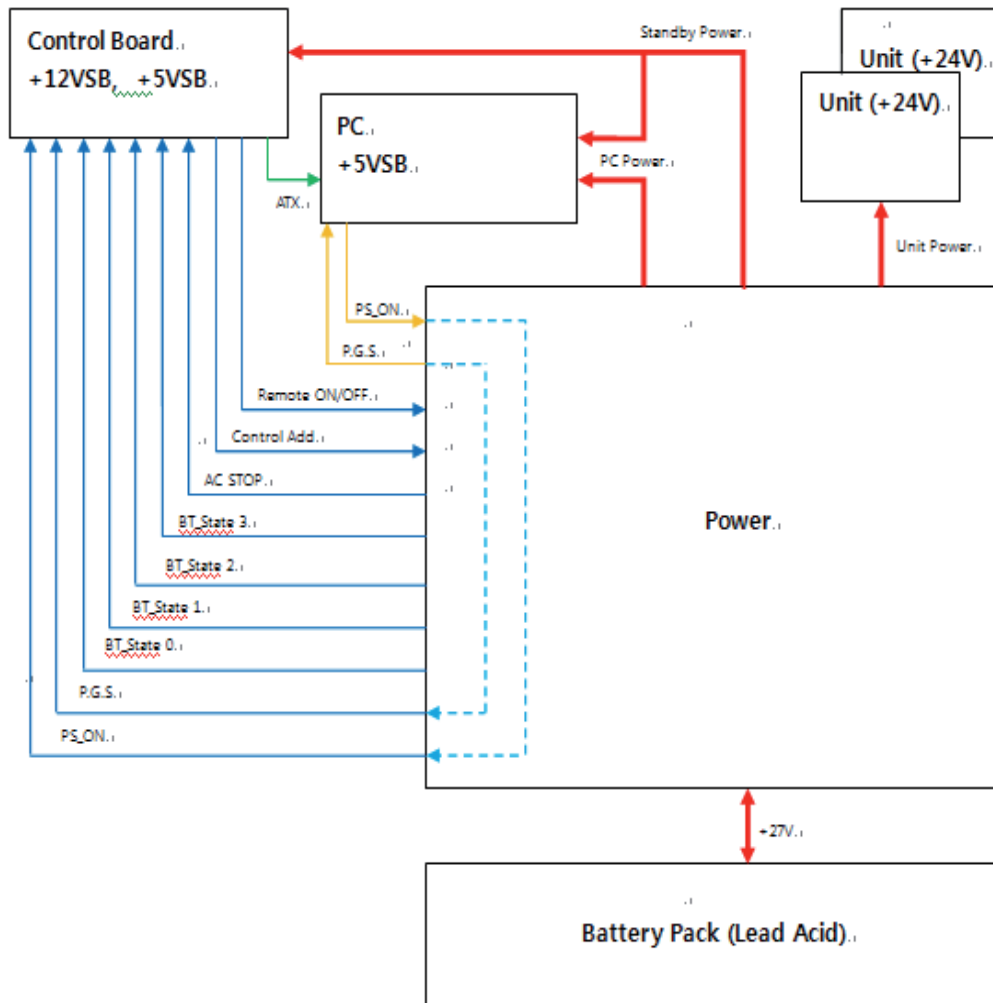

- (Blue) : Control Signal (Control B/D ↔ Power)
- (Green) : Control Signal (Control B/D ↔ PC)
- (Red) : Power

2. Mechanical Specification

2.1. Case Size

(W) X (D) X (H) mm : 189 X 360 X 120mm (without lead-acid battery)

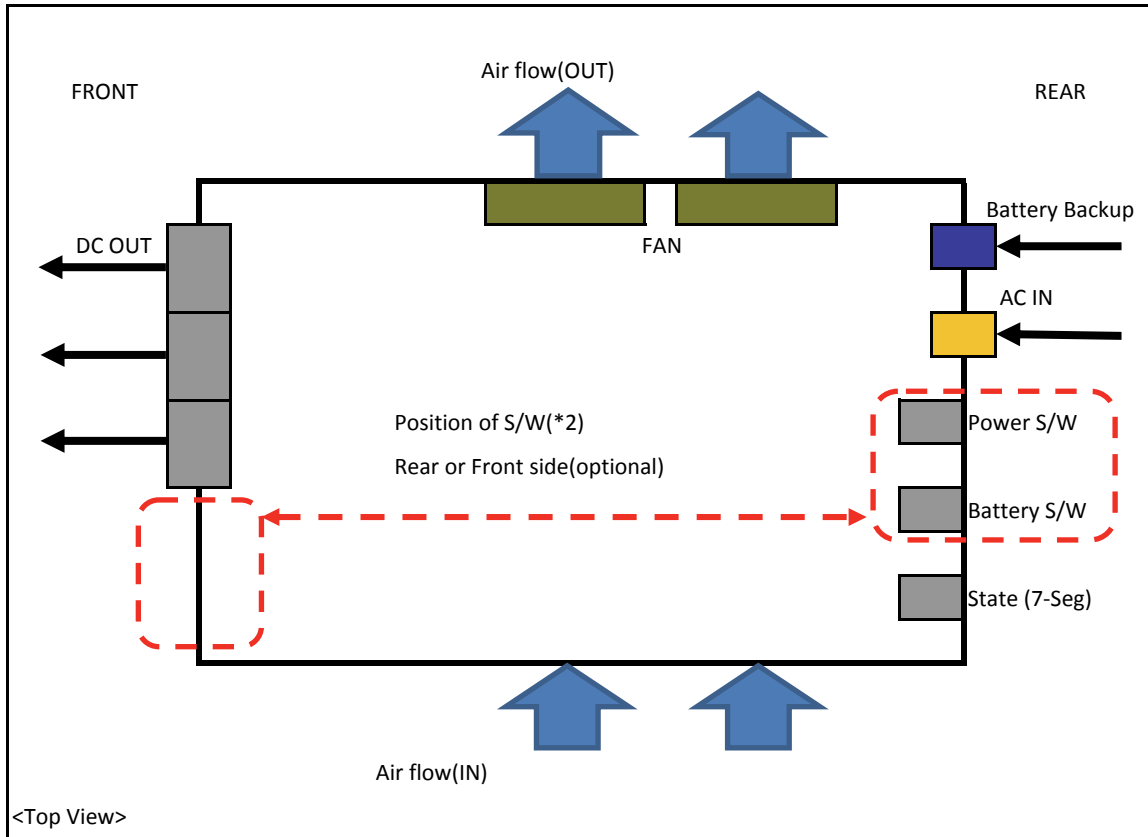

2.2. Component Arrangement

Component	Location	Remarks
AC IN Connector	Rear	
Battery Connector	Rear	
FAN	Right	92*92*25, 2ea
Power S/W	Rear or Front	Default : Rear
Battery S/W	Rear or Front	Default : Rear **To prevent wrong control**
Bracket of Power S/W, Battery S/W	Rear or Front	
DC OUT Connector	Front	
7-Segment of function state	Rear	
Air flow - IN (Cold)	Left	
Air flow - OUT (Hot)	Right(FAN)	
Carry Handle	Rear	

☞ Do not fix the Battery on Power Case.

3. Electrical specification

3.1. General specification

Items	Specification & Description	Remarks
Coverision Mode	AC/DC and DC/DC	
Efficiency	More than 75%	At rated Load
Operation Time	24hours (Continually) / 1 Day	At rated Load
Operation Temperature	Operating : -5°C ~ +40°C Storage : -20°C ~ +60°C	
Humidity	Operating : 20 ~ 80% Storage : 10 ~ 85%	
Vibration	Operating : 0.5G Storage : 2G	
Shock	Operating : 2G Storage : 5G	
ESD	Contact : 10KV Non-Contact : 10KV	
EMC	EMC : Class A	
Noise	FCC : Class A	
Safety	UL (Optional)	
Safety Certificate	With ATM System	
RoHS	RoHS	
Insulation resistance	Between AC input-FG, FG-Secondary : 50MΩ (Input Volt DC 500V)	For 1 minute
Withstand Voltage	Between AC input -FG, Primary-Secondary : AC 1.5kV (Cut-off current 10mA)	For 1 minute
Remote Sense	N/A	
Remote Control	Be Applicable	
Input Switch	Twin	
Input Fuse	250V 20A, slow-blow-type	One side for live line
Battery Fuse	32V 50A	One side for positive line
Cooling	Air cooling by FAN	
Thermal Protection	Be Applicable	
DC-Fan RPM Control	N/A	
MTBF	50,000Hours	
Life time	6 years with system condition	
Dimension	189(W) x 360(D) x 120(H) mm	Without mounting hole.
Weight	5.5Kg	
In/Out type	Connector / Connector	

3.2. AC Input

Items	Specification & Description	Remarks
Voltage	AC 110V or AC 220V	Free voltage
Voltage Range	AC 90V ~ AC 242V	
Current	12A(AC 110V) / 6A(AC220V)	At rated Load
Phase / Line	1 Phase / 2 Line	
Frequency	50 ~ 60 Hz	
Frequency Range	+2%, -4%	
Inrush Current	Less than 50A	
Leakage Current	Less than 10mA	
Insulation Class	Grounding	Condition in Grounding sourced

3.2.1. Catastrophic Failure Protection

- Flame, Excessive smoke, Charred PCB, Fused PCB conductor, Startling noise, Emission of molten material

3.3. DC output

3.3.1. Stand-by Power

Items	Specification & Description		Unit	Remarks
	+5VSB for PC & Control	+12VSB for Control		
Output Setting	+5.1	+12.2	V	at B/P, Min load
Tolerance	±5	±5	%	
Io	Minimum	0	A	
	Rated	1	A	Continuous
	Maximum	-	A	
	Peak	1,5	2,5	A
Ripple / Noise	50 / 150	120 / 240	mVpp	
OVP	5.6 ~ 6.8	13.5 ~ 16.3	V	Ref. to #1
OCP	1.5 ~ 8.0	2.5 ~ 8.0	A	
Protection Characteristics	Latch Shut Down or Auto-Recovery		-	OCP State
Ref. #1 Zener Protection and Shut-down (Not Auto-Recovery)				

3.3.2. PC Power

Items	Specification & Description					Unit	Remarks	
	+3.3V	+5V	+12V	-12V	+5VSB			
Output Setting	+3.4	+5.15	+12.4	-12.0	See 3.3.1	V	at B/P, Min load	
Tolerance	±5	±5	±5	±10		%		
Io	Minimum	2	3	3		0	A	
	Rated	10	14	16		0,5	A	Continuous
	Maximum	-	20	20		-	A	5s
	Peak	11	21	21		1,5	A	10mS
Ripple / Noise	50 / 150	50 / 150	120 / 240	120 / 240		mVpp		
OVP	3.7 ~ 4.7	5.6 ~ 8.0	14 ~ 18	N/A		V		
OCP	11 ~ 15	21 ~ 26	21 ~ 26	S.C		A		
Protection Characteristics	Latch Shut Down			Latch Shut Down or Auto Recovery		-	OVP, OCP State	
Remote-Sensing	O	O	X	X	-	Ref. to #1		
Ref. #1 Remote-Sensing Point : Default - Backplane connector (Option - PC B/D connector)								

3.3.3. Unit Power

Items	Specification & Description		Unit	Remarks
	+24V			
Output Setting	+25.8		V	at B/P, Min load
Tolerance	+13/-4 (23.04V~27.12V)		%	
Io	Minimum	0/2	A	
	Rated	25	A	Continuous
	Maximum	45	A	200mS
	Peak	50	A	10mS
Ripple / Noise	250 / 500		mVpp	
OVP	27.5 ~ 34.0		V	
OCP	50 ~ 60		A	
Protection Characteristics	Latch Shut Down		-	OVP, OCP State

Remarks : 3.3.1~3.3.3 Duty Ratio between Max and Peak output current

Max vs. Rated Current Duty Ratio → 1 : 9 (To keep the Max loading on all outputs)

Peak vs. Rated Current Duty Ratio → 1 : 99 (To keep the peak loading on each output)

3.3.4. Battery Back-up Function

Items	Specification & Description		Unit	Remarks
	Lead-Acid : +24V			
Charger	Charge Method	CV	-	
	Charge Voltage	+27.0 ± 0.2	V	
	Over Charge Voltage	+27.2 ± 0.2	V	Ref. to #1
	Over Charge Voltage Reset	+26.8 ± 0.2	V	Ref. to #2, Comment
	Charge Current	0.1 ~ 1.2	A	
	OCP	More than 2.5 ± 0.3	A	
	Protection Mode	Charge Stop	-	OCP
	Charge Time	About 10 (Max)	Hour	Just Ref.
Charge Start Condition	AC off & on switch cycling AC re-input after AC interruption Battery detection Auto charge	-	Ref. to #4	
Discharge	Low Battery State	+22.0 ± 0.5	V	Ref. to 3.5.2
	Discharge Voltage	+21.0 ± 0.5	V	Ref. to #3
	Discharge current	No limitation	A	
	Discharge Time	Min 6.0	Minute	
Ref. #1 When the battery voltage maintains over the specification for more than one second, stop charging the battery.				
Ref. #2 If the battery voltage is over the specification, do not start to charge the battery.				
Ref. #3 If the battery voltage maintains under the specification for more than one second, stop charging the battery.				
Ref. #4 Stop charging after detection battery full and charge the battery automatically, when a few days elapses.				

3.3.5. Efficiency

Loading	Rated Load (100%)
Efficiency	More than 75%

3.3.6. Output Transient Response

Output	Max. step size	Output	Max. step size
+24VDC	10A	-12VDC	0.1A
+12VDC	6.4A	+5VSB	0.5A
+5VDC	4.2A	+12VSB	0.5A
+3.3VDC	3.0A		

- The transient load slew rate is = 1.0 A/ μ s.
- All output voltages stay in regulation.
- Load-changing repetition rate of 50 Hz to 10 kHz
- AC input range : 90VAC ~ 264VAC

3.3.7. Capacitive Load

Output	Capacitive load	Output	Capacitive load
+24VDC	7,000 μ F	-12VDC	200 μ F
+12VDC	470 μ F	+5VSB	330 μ F
+5VDC	3,000 μ F	+12VSB	330 μ F
+3.3VDC	2,000 μ F		

3.3.8. +5 VDC / +3.3 VDC Power Sequencing

The +12 VDC and +5 VDC output levels must be equal to or greater than the +3.3 VDC output at all times during power-up and normal operation. The time between the +12 VDC or +5 VDC output reaching its minimum in-regulation level and +3.3 VDC reaching its minimum in-regulation level must be ≤ 20 ms.

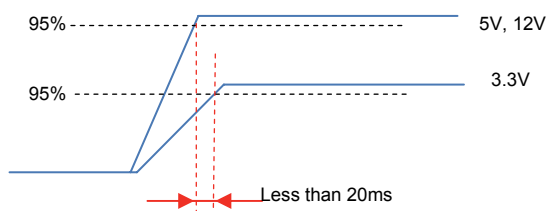

3.3.9. Voltage Hold-up Time

T7 ≥ 17 ms (115VAC/47 Hz or 230VAC/47 Hz) at rated-load (100%)

3.4. Timing / Housekeeping / Control

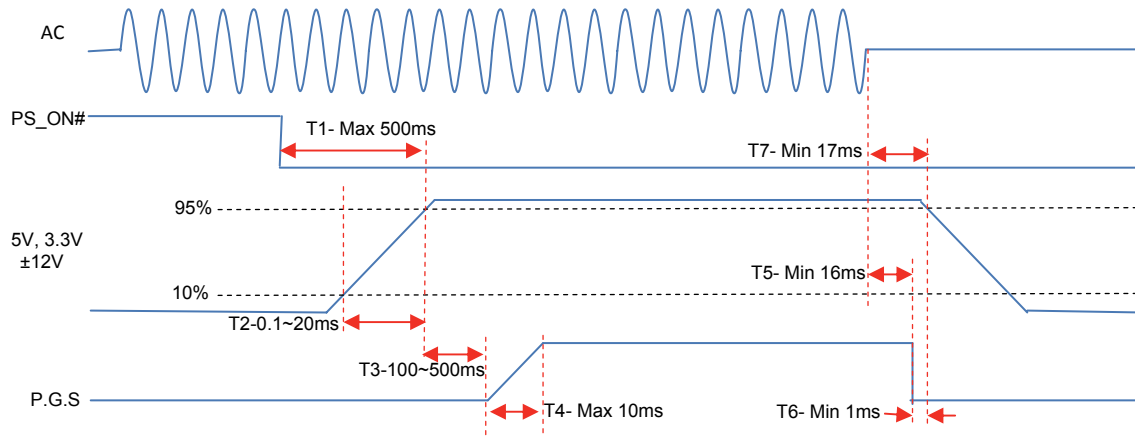

3.4.1. P.G.S (PWR_OK)

Signal Type	Spec	Remarks
Logic level Low	No PC Power < 0.4V while sinking 4mA	Power → PC (→ Control B/D)
Logic level High	PC Power normal operation Between 2.4V and 5V output while sourcing 200uA	
High-state output impedance	1kΩ from output to common	
P.G.S_OK delay	100ms < T3 < 500ms	
P.G.S_OK risetime	T4 ≤ 10ms	
AC loss to P.G.S_OK hold-up time	T5 ≥ 16ms	
Power-down warning	T6 ≥ 1ms	

3.4.2. PS_ON#

Signal Type	Spec	Remarks
Logic level Low	Send a event PC Power ON	PC → Power (→ Control B/D)
Logic level High	Send a event PC Power OFF (+3.3V, +5V, +12V, -12V Power)	
V _{IL} Input Low Voltage	0.0V ~ 0.8V	
I _{IL} Input Low Current (V _{in} =0.4V)	Max. -1.6mA	
V _{IH} Input High Voltage (I _{in} =-200μA)	Min. 2.0V	
V _{IH} open circuit, I _{in} =0	Max. 5.25V	

3.4.3. Power-on Time

Description	Spec
Delay from PS_ON# is pulled low to output voltages(+12VDC, +5VDC and +3.3VDC) within the regulation limits.	T1 < 500 ms
Delay from PS_ON# is pulled low to output voltages(+24VDC) within the regulation limits.	Max. 1000ms
Delay from AC being to +5VSB within regulation limits.	Max. 2000ms

3.4.4. Rise Time

Description	Spec
Delay from output voltage is rise $\leq 10\%$ to within the regulation limits.	0.1ms < T2 < 20 ms

3.4.5. Overshoot at Turn-on / Turn-off

Description
The output voltage overshoot upon the application or removal of the input voltage, or the assertion/deassertion of PS_ON#, under the conditions specified in Section 3.2, shall be less than 10% above the nominal voltage . No voltage of opposite polarity shall be present on any output during turn-on or turn-off.

3.4.6. Reset after Shutdown

Description
If the power supply latches into a shutdown state because of a fault condition on its outputs, the power supply shall return to normal operation only after the fault has been removed and the PS_ON# (or AC input) has been cycled OFF/ON with a minimum OFF time of 3 second.

3.5. Switch / Control Signal Specification

3.5.1. Switch

Switch name	Spec	Remarks
Power ON/OFF Switch	AC Input and Stand-by Power On/Off control	User → Power
Battery ON/OFF Switch	On/Off control of the battery connection	User → Power

3.5.2. Control Signal

Signal name	Spec	Remarks
Remote ON/OFF Signal	Logic level Low : Event a Unit Power OFF Logic level High : Event a Unit Power ON (24V Power) Note, only to be operation in the low status of PS-ON signal	Control B/D → Power
Control Add	Logic level Low : Control B/D connecting status. Logic level High : Control B/D dis-connecting status.	Control B/D → Power
AC STOP	Logic level Low : AC failure status. (AC STOP) Logic level High : AC Power-on status.	Power → Control B/D
BT_State0	Battery status (by Bit combination) References ; 3.5.3. BT_State Signal Bit combination	Power → Control B/D
BT_State1		
BT_State2		
BT_State3		

3.5.3. BT_State Signal Bit combination

BT_State Signal				Spec	Remarks
BT_State3	BT_State2	BT_State1	BT_State0		
0	0	0	0	Good	
0	0	0	1	Reserve	
0	0	1	0	Battery No Connection	
0	0	1	1	Battery ON/OFF Switch OFF	
0	1	0	0	Temp Caution (Under -5°C)	TH1
0	1	0	1	Temp Caution (70°C ~ 80°C)	TH1
0	1	1	0	Temp Warning (Over 80°C)	TH1
0	1	1	1	Temp NG (etc)	
1	0	0	0	Reserve	
1	0	0	1	Battery Caution (22V ~ 24V)	
1	0	1	0	Battery Warning (Under 22V)	Low Battery
1	0	1	1	Reserve	
1	1	0	0	Reserve	
1	1	0	1	Reserve	
1	1	1	0	Reserve	
1	1	1	1	N.C	

• The BT_State is defined a priority for the large number.

Ex) In case of Temp Caution and Battery Caution is coincided at same time, The BT_State will be displayed Battery Caut

• Battery Status detection detail

Items	ON condition	OFF condition	Recovery Method
Battery No Connection	Battery \leq +5.0V	N/A	Battery Switch OFF/ON
	Battery Switch OFF	Battery Switch ON	N/A
Battery Caution	Battery \leq +24.0V	Battery \geq +24.3V	Auto Recovery
Battery Warning	Battery \leq +22.0V	Battery \geq +22.3V	Auto Recovery

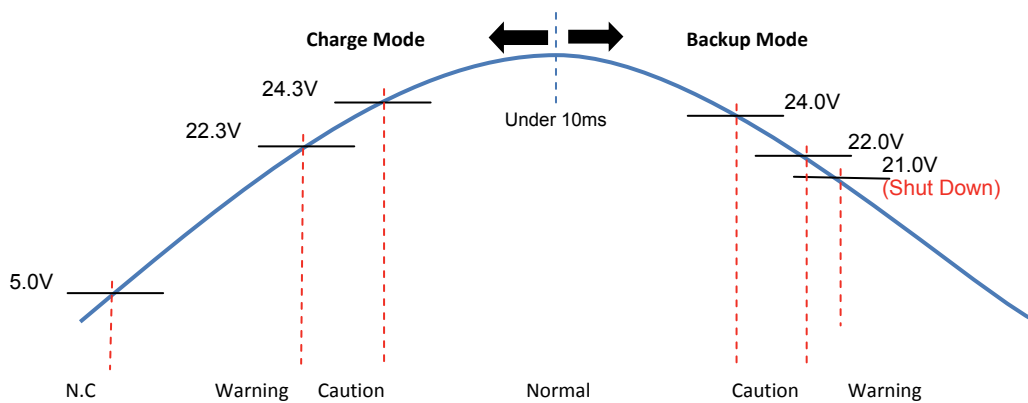

3.6. 7-Segment Indication spec

3.6.1. Event of Power ON stage / Special status / N.G status

; Display the status of Power supply on the 7-Segment in Rear side of power supply.

Segment	Indication Contents	Remarks
0	Normal status / Full charging of Battery	Power ON
1	Remote ON Signal active Low for +24V turn-off	
2	P.G.S Signal active High	
3	PS_ON Signal active LOW	
4	AC IN	
5	Reserve (Special status)	Special Status
6	Status of AC STOP / Battery Backup	
7	No PFC operation	N.G event of Power supply. Self-checking mode.
8	No 24VDD operation	
9	Reserve (Special status)	
A	+12VSB OCP Shut-Down	
b	-12VDC OCP Shut-Down	
C	+3.3VDC OCP Shut-Down	
d	+5VDC OCP Shut-Down	
E	+12VDC OCP Shut-Down	
F	+24VDC OCP Shut-Down	
H	OVP Shut-Down	
L	TH1 OTP Shut-Down (Over 80°C of Heatsink)	
P	TH3 OTP Shut-Down (Over 60°C inside of power supply)	
9.	+5VSB Regulation N.G	
A.	+12VSB Regulation N.G	
b.	-12VDC Regulation N.G	
C.	+3.3VDC Regulation N.G	
d.	+5VDC Regulation N.G	
E.	+12VDC Regulation N.G	
F.	+24VDC Regulation N.G	

• The 7-Segment is defined a priority for the smaller number.

Comment : - Micom can not operate at +5VSB shut-down, so regulation fault just will be displayed with 9 and dot (9.)

3.6.2. Display of Battery status

; From the normal operation of display "0", The 7-segment is defined as follows ;

Battery	Display 1 (250ms)	Display 2 (250ms)	Display 3 (250ms)	Display 4 (250ms)	Remarks
Lead-Acid (Rotation on lower side)					Rotation of 1~4

(Note 1) The above display is only for the charging status of battery.

(Note 2) Battery charge will begin the battery after 10 second from the P.G.S Signal ON.

(Note 3) Return to the display of PSU status when there is a fault on PSU condition.

(Note 4) It will be a recovery status of "0" after the battery is charged fully.

3.6.3. PS ON/OFF

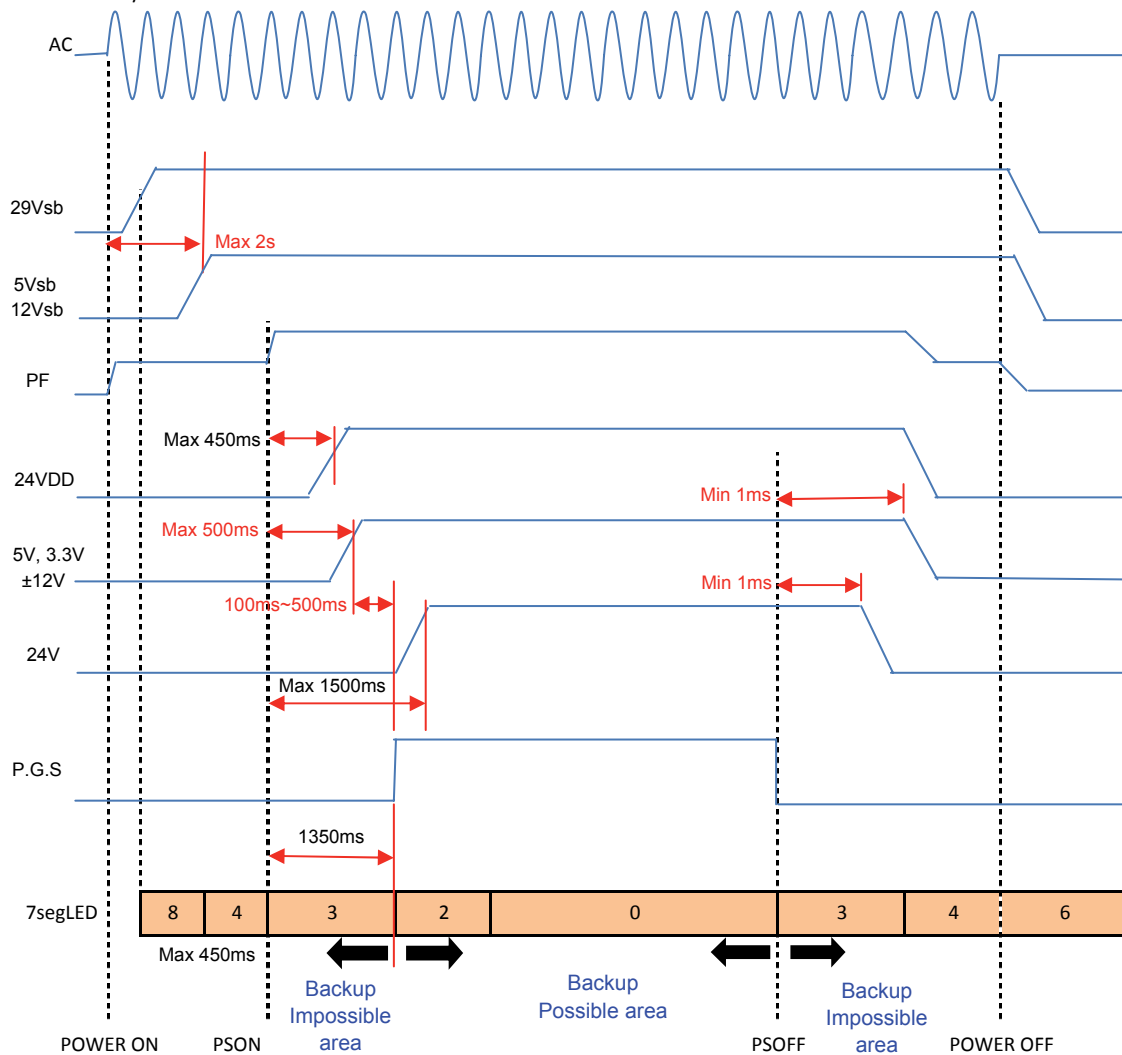

(Note 1) Do not accept PS ON signal for 100mS, after +5VSB, +12VSB ON.

(Note 2) Do not accept PS ON signal for 2000mS, after PS OFF.

3.6.4. Shut Down

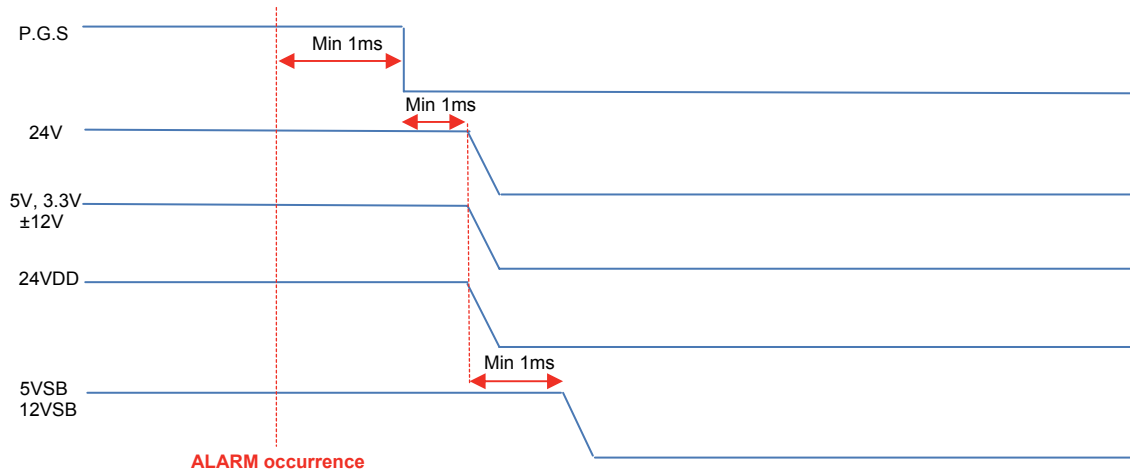

[Shut Down Factors]

- (1) Output Faults (PF, 24VDD, 24V, $\pm 12V$, 5V, 3.3V, 12VSB, 5VSB)
- (2) Heatsink Temp : Over 80°C more than 10 seconds.
- (3) Inside Temp : Over 60°C more than 10 seconds.
- (4) Blackout when no connection of Battery and BAT switch OFF
- (5) At Battery Discharge Stop Voltage of 21Vdc detection when Battery Backup status.

※ Note, The status of 5VSB, 12VSB will be On status in the Alarm status except for 5VSB, 12VSB.

3.6.5. ALARM definition

Items	5VSB, 12VSB	12V, 5V, 3.3V, -12V	24V	Remarks
Standby Power ALM	X	X	X	O: Output ON X: Output OFF
PC Power ALM	O	X	X	
UNIT Power ALM	O	X	X	

3.6.6. Backup

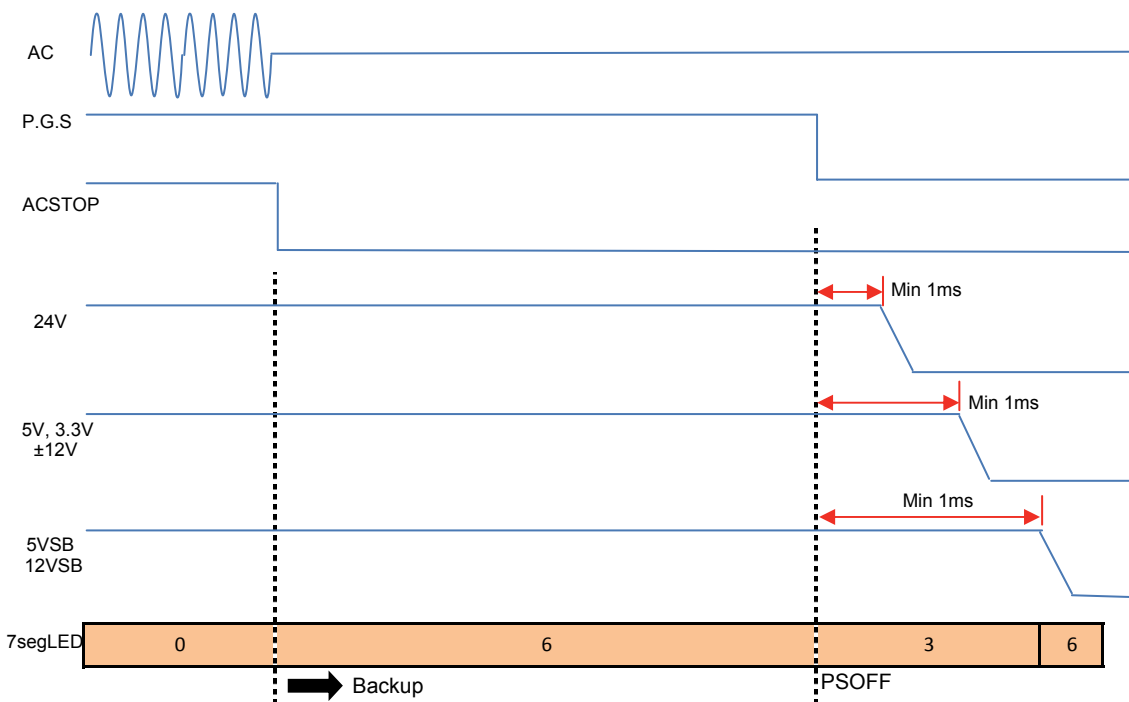

3.6.7. Recovery

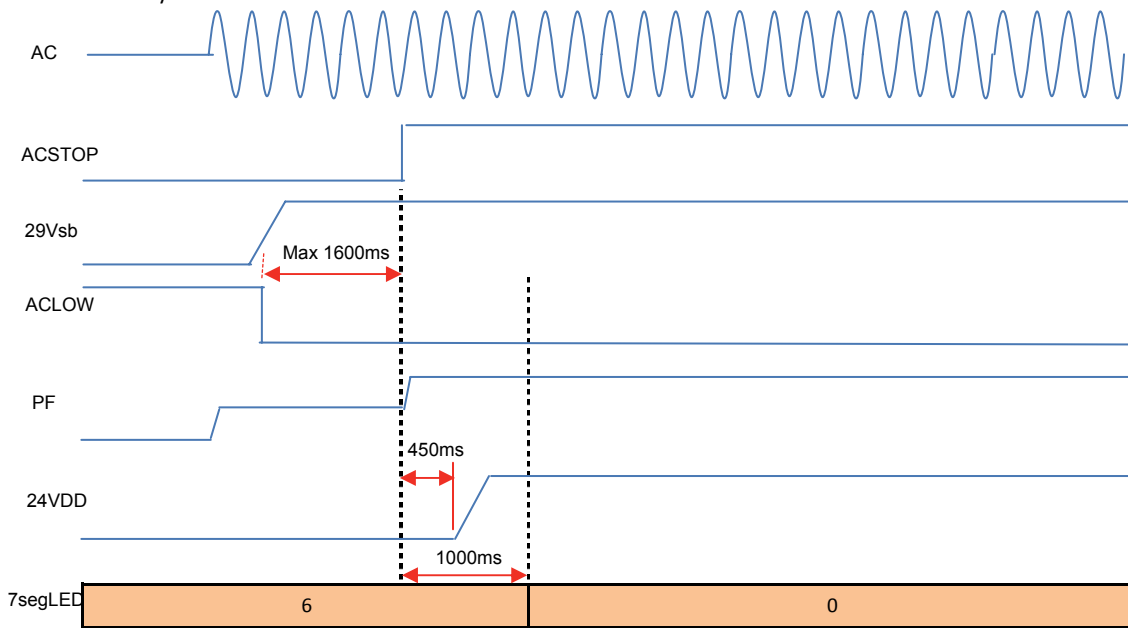

3.6.8. Remote ON/OFF

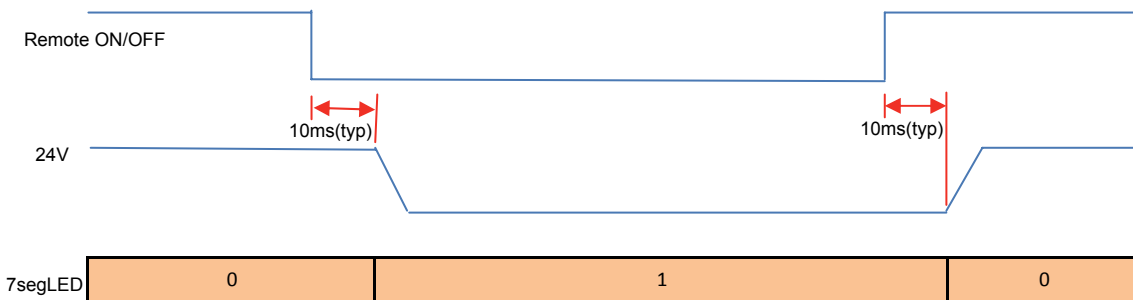

3.7. Output Protection

3.7.1. Over-voltage Protection

Output	Min.	Nor.	Max.	Unit	Power State
+24VDC	27,5	31,0	34,0	Volts	Latch Shut-down
+12VDC	13,4	15,0	15,6	Volts	
+5VDC	5,7	6,3	7,0	Volts	
+3.3VDC	3,8	4,2	4,3	Volts	

3.7.2. Short-circuit Protection

Output	Power State
+24VDC	Latch Shut-down
+12VDC	
+5VDC	
+3.3VDC	
-12VDC	Latch Shut-down or Auto-Recovery
+5VSB/+12VSB	

3.7.3. No-Load Operation

No damage or hazardous condition (all the DC output connectors disconnected from the load)

3.7.4. Over-current Protection

Output	Min.	Max.	Unit	Power State
+24VDC	50	60	Amps	Latch Shut-down
+12VDC	21	27	Amps	
+5VDC	21	27	Amps	
+3.3VDC	11	16	Amps	
+5VSB	1,5	8,0	Amps	Latch Shut-down or Auto-Recovery
+12VSB	2,5	8,0	Amps	

3.7.5. Over-temperature Protection

Sensor	Sensor location / Spec	Power State
TH1	Heatsink-3, 80°C ± 5°C	Latch shut-down
TH3	TOP PCB, 60°C ± 5°C	

5. Other specification

5.1. 7-Segment Sticker

; The label of 7-Segment will be affixed to the sides of the power supply.

Segment	Indication Contents
0	Normal status / Full charging of Battery
1	Remote ON Signal active Low for +24V turn-off
2	P.G.S Signal active High
3	PS_ON Signal active LOW
4	AC IN
5	Reserve (Special status)
6	Status of AC STOP / Battery Backup
7	No PFC operation
8	No 24VDD operation
9	Reserve (Special status)
A	+12VSB OCP Shut-Down
b	-12VDC OCP Shut-Down
C	+3.3VDC OCP Shut-Down
d	+5VDC OCP Shut-Down
E	+12VDC OCP Shut-Down
F	+24VDC OCP Shut-Down
H	OVP Shut-Down
L	TH1 OTP Shut-Down (Over 80°C of Heatsink)
P	TH3 OTP Shut-Down (Over 60°C inside of power supply)
9.	+5VSB Regulation N.G
A.	+12VSB Regulation N.G
b.	-12VDC Regulation N.G
C.	+3.3VDC Regulation N.G
d.	+5VDC Regulation N.G
E.	+12VDC Regulation N.G
F.	+24VDC Regulation N.G
Rotation	Good / In charging mode of Battery

5.2. FAN Specification

Items	Spec	Remarks
FAN	SUNON, KD1209PTB2, 92*92*25, 12V, 0.2A, 48.5CFM	2EA

5.3. Packing Specification

- This product should be properly packed to prevent for any damages or moisture during delivery.
- Both companies regulate for the package spec under consent.

6. Structure

6.1. General Specification of Structure

6.1.1. The demension of power supply shall be meet the spec.

6.1.2. All materials of this product should be replaceable without any bad effects on function or performance.

6.1.3. All materials should not occur any toxic/corrosive gases which is harmful to humans or system operation during operation/handling.

6.1.4. All materials should not affect on any other equipments or components nearby due to malfunction.

6.1.5. weight

Power Supply	2.9Kg
Chassis	2.6Kg
Total weight	5.5Kg

6.2. Mechanical Structure Specification

6.2.1. The metal surraces of the product should be properly managed for preventing corrosion and should be no vibration loosening.

6.2.2. The quality of material should be as requested or better. Especially, surface treatment for Aluminum/Iron is necessary.

6.2.3. Power input/output connector and power switch should be installed in the product as requested.

7. Inspection Specification



- An inspection for this product should be carried out based on the attached the test report.

8. Reliability

- Warranty : Once delivered, the quality guaranteed for 12 Months with no extra charge, however, it will be handled at an actual expense when the product is damaged by user's carelessness or the warranty seal is destroyed.

- Quality Assurance : The PSU should be modified/investigatged in the aspect of quality or technique as customer's request.

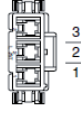
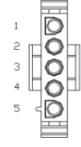
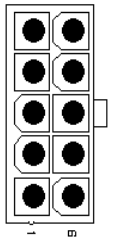
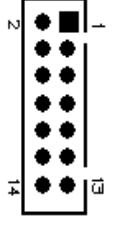
9. Connector Specification

Items	Connector No.	Pin No. : spec	Vendor	Part No.	Remarks
AC IN 	CN1	1 : AC IN (Line) 2 : FG 3 : AC IN (Neutral)	JST	VLR-03V	Rear
Battery 	-	1 : GND 2 : GND 3 : Battery CHK 4 : +24V 5 : +24V	AMP	1-480763-0	Rear (AWG14) Battery CHK Spec - Lead-Acid Type : Grounding
Controller Power 	CON10	1 : +24V 2 : +24V 3 : +12VSB 4 : +12VSB 5 : +5VSB 6 : GND 7 : GND 8 : GND 9 : GND 10 : GND	YEONHO MOLEX	SMH420-10 5566-10	Front
Controller I/O 	CON2	1 : Remote ON/OFF (IN) 2 : Control Add (IN) 3 : AC STOP (OUT) 4 : PS_ON [PWR] (OUT) 5 : P.G.S [PWR] (OUT) 6 : BT_State0 (OUT) 7 : BT_State1 (OUT) 8 : BT_State2 (OUT) 9 : BT_State3 (OUT) 10 : GND 11 : NC 12 : NC 13 : NC 14 : NC	HIROSE	DF11-14DP -2DSA	Front
MCU 	CON11	1 : +3.3V 2 : +3.3V 3 : GND 4 : +5V 5 : GND 6 : +5V 7 : GND 8 : P.G.S (OUT)	YEONHO MOLEX	SMH420-24 5566-24	Front

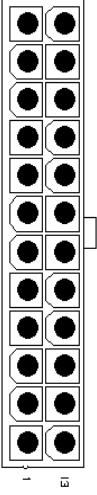
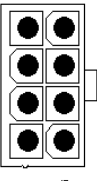
		9 : +5VSB 10 : +12V 11 : +12V 12 : +3.3V 13 : +3.3V 14 : -12V 15 : GND 16 : PS_ON (IN) 17 : GND 18 : GND 19 : GND 20 : NC 21 : +5V 22 : +5V 23 : +5V 24 : GND			
MCU1 	CON12	1 : +5V 2 : +5V 3 : +12V 4 : +12V 5 : GND 6 : GND 7 : GND 8 : GND	YEONHO MOLEX	SMH420-08 5566-08	Front
10 B/D	CON7	1 : +5V 2 : +5V 3 : +12V 4 : +12V 5 : GND 6 : GND 7 : GND 8 : GND	YEONHO MOLEX	SMH420-08 5566-08	Front
Reserve (+5V, +12V)	CON8	1 : +5V 2 : +5V 3 : +12V 4 : +12V 5 : GND 6 : GND 7 : GND 8 : GND	YEONHO MOLEX	SMH420-08 5566-08	Front

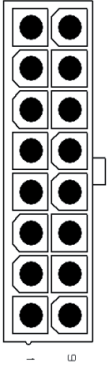
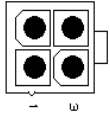
BRU	CON9	1 : +24V 2 : +24V 3 : +24V	YEONHO MOLEX	SMH420-16 5566-16	Front
		4 : +24V 5 : +24V 6 : +24V 7 : +24V 8 : +24V 10 : GND 11 : GND 12 : GND 13 : GND 14 : GND 15 : GND 16 : GND			
CIP	CON6	1 : +24V 2 : +24V 3 : GND 4 : GND	YEONHO MOLEX	SMH420-04 5566-04	Front
					
PPR	CON5	1 : +24V 2 : +24V 3 : GND 4 : GND	YEONHO MOLEX	SMH420-04 5566-04	Front
CDU	CON13	1 : +24V 2 : +24V 3 : GND 4 : GND	YEONHO MOLEX	SMH420-04 5566-04	Front
A4 PRINTER	CON14	1 : +24V 2 : +24V 3 : GND 4 : GND	YEONHO MOLEX	SMH420-04 5566-04	Front
FAN	CON4	1 : +24V 2 : +24V 3 : GND 4 : GND	YEONHO MOLEX	SMH420-04 5566-04	Front
RESERVE	CON15	1 : +24V 2 : +24V 3 : GND 4 : GND	YEONHO MOLEX	SMH420-04 5566-04	Front

ISP	J3	1 : MCLR (Master Clear Reset) 2 : +5VSB 3 : GND 4 : ISP PGD 5 : ISP PGC	MOLEX	0022032061	Front
