

RDSAGUPS 240 WATT DIN RAIL DC-UPS SAG BUFFER, and OPTIONAL EXTERNAL BATTERY



DC-UPS Sag Buffer and External Battery

FEATURES

- ◆ Up to 10 extra minutes holdup time with optional external Backup Battery Pack. (Battery Packs available separately)
- ◆ 700 mSec. backup time at 10A full load, (no Ext. Battery)
1 min. backup time at 10A full load (with Ext. Battery)
- ◆ < 1 mS output transition time at 10 A full load
- ◆ "DC OK" monitor signal
- ◆ "CHARGING" visual indicator LED
- ◆ Overload and Short Circuit Protections
- ◆ Compact Size
- ◆ Industrial design and rugged metal construction quality
- ◆ Meets UL/C-UL, EN 50081-2, EN 61000-6-2
- ◆ Low EMI meets EN55022, FCC15, EN55024 standards

DESCRIPTION

A system power solution. The DC-UPS (Uninterruptible Power Source) is a DIN RAIL system power solution offering high quality, performance and value. The DC-UPS Sag-Buffer charger controls 24 VDC loads while simultaneously charging the optional external Battery Pack.

State of the art technology. A fast transition time from the DC input power to the DC-UPS/BATTERY system provides uninterrupted power to the system load. This increases reliability for industrial and critical system applications.

Easy installation, safety and reliability. These units have a rugged metal case and a secure metal DIN Rail mounting clip. The Battery Pack has an easily accessible circuit protection fuse with a dedicated cable connection to the DC-Sag-UPS module. DIN screw terminals are easily accessible to ensure a safe and reliable installation. (2)

INPUT SPECIFICATIONS

| | |
|----------------------|-------------------------------------|
| Input Voltage rating | 24 VDC +/- 5%, |
| Input Current (1) | 11 A (unit's internal usage: < 1 A) |
| Fuse Protection | Front Access, 250 VAC, 12A rating |

ENVIRONMENTAL

| | |
|-----------------------|--------------------------|
| Operating Temperature | 0 °C to +75 °C |
| Storage Temperature | -15 °C to +75 °C |
| Operating Humidity | ≤ 95% RH, non-condensing |
| Vibration / Shock | 2.3g, 90min / 30g |

GENERAL SPECIFICATIONS

| | |
|---------------------------|--|
| Construction | Industrial, rugged metal case. |
| Connectors / Terminals | Screw terminals, battery cable |
| DIN Rail Mounting Bracket | Metal, Secure snap-on spring-loaded clip |
| Adjustable Settings | Fixed output voltage and set points |
| Efficiency (1) | 1 A internal use by the DC-UPS unit |
| Cooling | Free air, ambient 10–60°C |
| Status Indicators | "CHARGING" LED and "DC-OK" monitor signal |
| Charging Time (1) | 4 hrs max |

OUTPUT SPECIFICATIONS

| | |
|--------------------------|---|
| Total Output Power | 240 Watts |
| Output Voltage / Current | 24 V, 10 A to the load |
| Minimum Load | No minimum load required |
| Hold Up Time: | |
| no external battery: | 700 mS. at 10A full load |
| with external battery: | 1 Min. at 10A full load |
| Low Voltage Trip Points: | |
| Falling: | 22.7 V |
| Recovering: | 22.8 V |
| Low Voltage Boost | ≥ 22.1 V |
| Low Voltage Shutdown: | |
| From Battery: | ≤ 19.8 V |
| From DC Input | ≤ 22.3 V |
| Output Transition Time | < 0.8 ms, with < -10% DC output drop |
| Damage Protections | Front access fuses on DC-UPS and external Battery units |

EMC and SAFETY (2)

| | |
|----------------|---|
| Certifications | Safety meets UL508, UL/C-UL(60950). EMI meets FCC15-B, EN55022-B EN55024 |
|----------------|---|

NOTES

1. For Battery protection against damage, the external charger source connected to the Sealed Lead Acid Backup Battery module must only be the DC-Sag UPS model charger.
2. Products are rated for industrial environments and are not to be used nor are warranted in aerospace, medical or lifesafety applications.

OUTPUT VOLTAGE / CURRENT RATINGS

| MODEL | VOLTAGE | INPUT CURRENT | OUTPUT CURRENT | MAX OUTPUT POWER |
|---|---------|---------------|----------------|------------------|
| RDSAGUPS DC-UPS Sag Buffer | 24 V | 11A Charging | 10 A Charging | 240 W |
| RDSAGUPS-BATTLA DC-UPS Battery Enclosure (Battery not included) | 24 V | 10 A Charging | 10 A / 1.3 AH | 240 W |

OUTPUT HOLD TIMES vs LOAD CURRENT

| Output Load Current | No External Battery | With External Battery |
|---------------------|---------------------|-----------------------|
| 1 Amp | 10 Sec | (tbd) |
| 5 Amp | 2 Sec | 2 Min |
| 10 Amp | 0.7 Sec | 1 Min |

MECHANICAL SPECIFICATIONS (inches / mm)

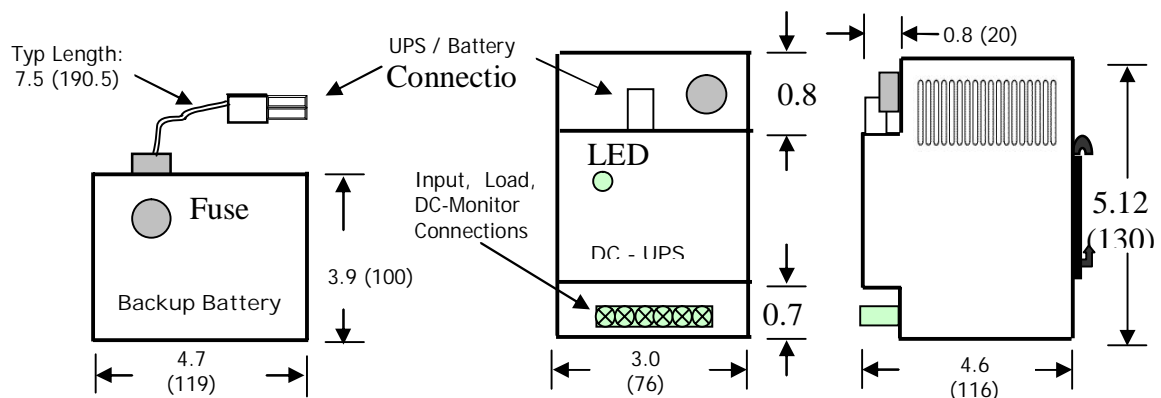

NOTES

1. DEPTH excludes the 0.3125" (9mm) DIN Rail mounting bracket.
2. WEIGHT for the DC-UPS Sag Buffer is 2.7 lbs (1.2 Kg) 'net' excluding packaging / shipping.
3. FUSES are AC 250V / 12A rating, user replaceable, 1 per unit.
4. BATTERY CABLE (+ / -) is a dedicated cable from the Battery unit to the DC-UPS unit only.
5. For external Battery protection against damage, the charger source connected to the Sealed Lead Acid Backup Battery unit must only be the DC-UPS Sag Buffer charger.

PIN ASSIGNMENTS

(DC-UPS Sag-Buffer Unit Screw Terminals)

1 8

| PIN No. | DESCRIPTION |  |
|---------|-----------------------|--|
| 1, 2 | (+) (+) DC IN 24V | (+) Input from external DC power supply (2 pins) |
| 3 | (-) DC IN 24V | (-) Input from external DC power supply (1 pin) |
| 4, 5 | (+) (+) DC OUT 24V | (+) Output to DC Load (2 pins) |
| 6 | (-) DC OUT 24V | (-) Output to DC Load (1 pin) |
| 7 | (+) DC OK | (+) Open Collector output monitor signal |
| 8 | (-) DC OK | (-) Open Collector output monitor signal |

NOTES

It is recommended that both Input (+) pins be connected to the DC power supply source and both Output (+) pins be connected to the load.

| LED Operation | DC OK Signal Operation |
|--|--|
| ON – Normal DC Input, Backup source is charging | CONDUCTING (5ma) – DC Input is Normal. |
| OFF – Low Voltage DC Input, Backup source is not charging | OPEN (Bvce 36V) – DC Input is not Normal. |

BLOCK DIAGRAM

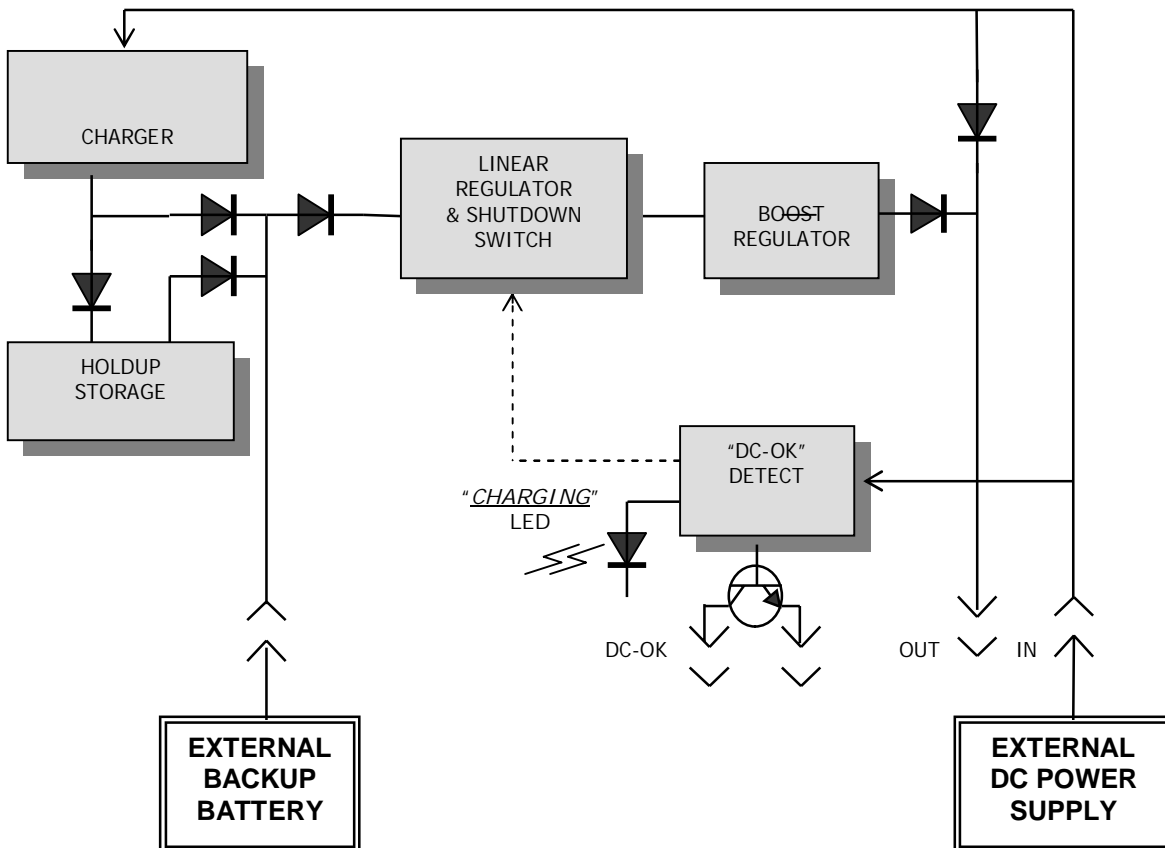

OPERATING STATES

The 24 VDC Input power source feeds the internal Charger. The DC-UPS Sag-Buffer Charger charges the Holdup Storage capacitor as well as the (optional) External Backup Battery. When the DC Input voltage becomes low, the DC-UPS Sag-Buffer switches its DC Output to the Battery source. The Linear Regulator and Boost Regulator work together to convert the energy of the Holdup Storage and Backup Battery to a regulated Holdup output voltage.

- NORMAL –** When the DC Input power source is normal and above the low voltage trip point, the DC Input voltage is routed to the DC Output terminals.
- LOW VOLTAGE –** When the DC Input power source fails or a transient occurs below the “Boost” trip point, the DC-UPS switches to the Internal Storage or optional Backup Battery source. The Linear Regulator and Boost Regulator maintain the DC Output energy at the Boost Voltage.
- SHUTDOWN –** When the Backup Battery fall below the ‘Automatic Shutdown’ point, the DC-OK Detection circuit automatically shuts off the DC OUT to the load. This protects the Battery from persistent overload and possible damage.
- RECOVERY –** If the DC-IN power source should recover, the Holdup circuit resumes normal operation and the Charger resumes charging the External Backup Battery.

OUTPUT TRANSITION (DC input power supply transitioning to DC-UPS battery power)

